

2A, Low Input Voltage, Low Dropout LDO Regulator with Enable

General Description

The Evaluation Board user guide describes the operational use of the RTQ2516-QT evaluation board as a reference design for demonstration and evaluation of the RTQ2516-QT, a low input voltage, low dropout LDO regulator with enable.

Included in this user guide are setup and operating instructions, thermal and layout guidelines, a printed circuit board (PCB) layout, a schematic diagram, and a bill of materials (BOM). For more detail information, please refer to the RTQ2516-QT datasheet.

Table of Contents

General Description	1
Performance Sepcification Summary	2
Power-up Procedure	2
Detailed Description of Hardware	4
Bill of Materials.....	5
Typical Applications	6
Evaluation Board Layout.....	8
More Information.....	9
Important Notice for Richtek Evaluation Board.....	9

Performance Specification Summary

Summary of the RTQ2516-QT Evaluation Board performance specification is provided in Table 1. The ambient temperature is 25°C.

Table 1. RTQ2516-QT Evaluation Board Performance Specification Summary

Specification	Test Conditions	Min	Typ	Max	Unit
Input Voltage Range		1.4	3.3	6	V
Output Current		0	--	2	A
Output Voltage Range		0.5	2.5	5.5	V
Line Regulation	$V_{OUT} + 0.5V \leq V_{IN} \leq 6V, V_{IN} \geq 2.2V, I_{OUT} = 100mA$	--	0.2	0.4	%
Load Regulation	$100mA \leq I_{OUT} \leq 1A$	--	0.5	1.5	%
Dropout Voltage	$I_{OUT} = 1A, V_{IN} \geq 1.6V$	--	120	200	mV
	$I_{OUT} = 1A, 1.4V \leq V_{IN} \leq 1.6V$	--	--	400	
	$I_{OUT} = 1.5A, V_{IN} \geq 1.6V$	--	180	300	
	$I_{OUT} = 1.5A, 1.4V \leq V_{IN} \leq 1.6V$	--	--	500	
	$I_{OUT} = 2A, V_{IN} \geq 1.6V$	--	240	400	
	$I_{OUT} = 2A, 1.4V \leq V_{IN} \leq 1.6V$	--	--	600	

Power-up Procedure

Suggestion Required Equipments

- RTQ2516-QT Evaluation Board
- DC power supply capable of at least 6V and 2A
- Electronic load capable of 2A
- Function Generator
- Oscilloscope

Quick Start Procedures

The Evaluation Board is fully assembled and tested. Follow the steps below to verify board operation. Do not turn on supplies until all connections are made. When measuring the output voltage ripple, care must be taken to avoid a long ground lead on the oscilloscope probe. Measure the output voltage ripple by touching the probe tip and grounding directly across the last output capacitor.

Proper measurement equipment setup and follow the procedure below.

- 1) With power off, connect the input power supply to VIN and GND pins.
- 2) With power off, connect the electronic load between the VOUT and nearest GND pins.
- 3) Turn on the power supply at the input. Make sure that the input voltage does not exceeds 6V on the Evaluation Board.
- 4) Check for the proper output voltage using a voltmeter.

- 5) Once the proper output voltage is established, adjust the load within the operating ranges and observe the output voltage regulation, quiescent current, dropout voltage, PSRR, noise and other performance.

Detailed Description of Hardware

Headers Description and Placement

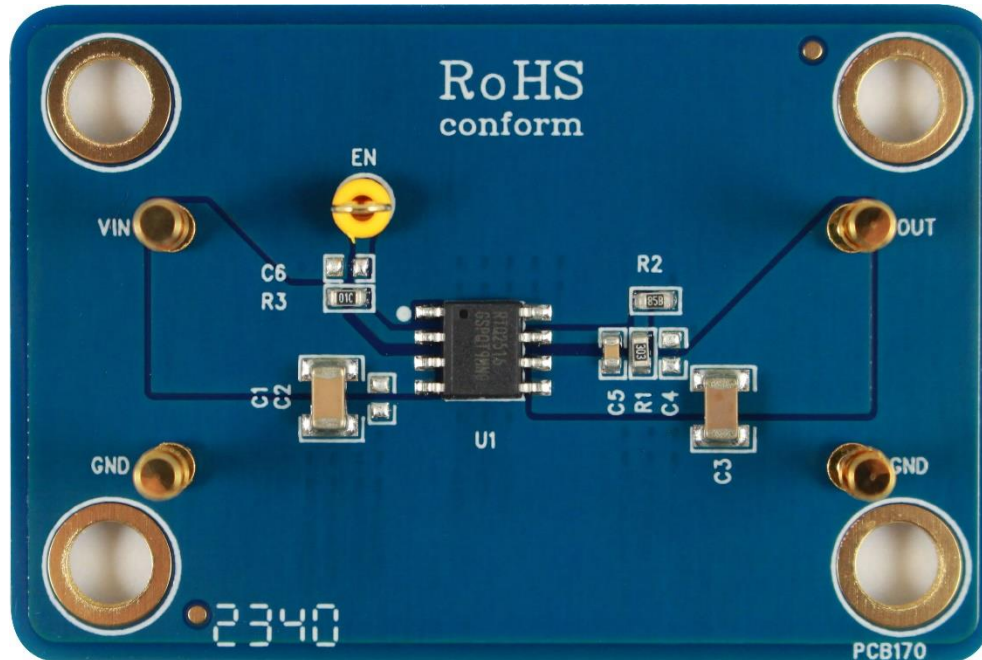

Carefully inspect all the components used in the EVB according to the following Bill of Materials table, and then make sure all the components are undamaged and correctly installed. If there is any missing or damaged component, which may occur during transportation, please contact our distributors or e-mail us at evb_service@richtek.com.

Test Points

The EVB is provided with the test points and pin names listed in the table below.

Test Point/ Pin Name	Function
VIN	Supply input pin.
VOUT	Output of the regulator.
EN	Enable sense pin.
GND	System ground pin.

Bill of Materials

VIN = 2.2V to 6V, VOUT = 0.8V to 5.5V, IOUT = 1A						
Reference	Count	Part Number	Value	Description	Package	Manufacturer
U1	1	RTQ2516GSP-QT	RTQ2516GSP-QT	LDO	SOP-8	RICHTEK
C1, C3	2	GCJ32EC71H106MA01	10μF	Capacitor, Ceramic, 50V, X7S	1210	MURATA
C2, C3, C4	3	GRM188R71H104KA93D	0.1μF	Capacitor, Ceramic, 50V, X7R	0603	MURATA
C5	1	0603B103K500CT	10nF	Capacitor, Ceramic, 50V, X7R	0603	WALSIN
R1	1	WR06X3002FTL	30k	Resistor, Chip	0603	WALSIN
R2	1	WR06X7501FTL	7.5k	Resistor, Chip	0603	WALSIN
R3	1	WR06X1002FTL	10k	Resistor, Chip	0603	WALSIN

Typical Applications

EVB Schematic Diagram

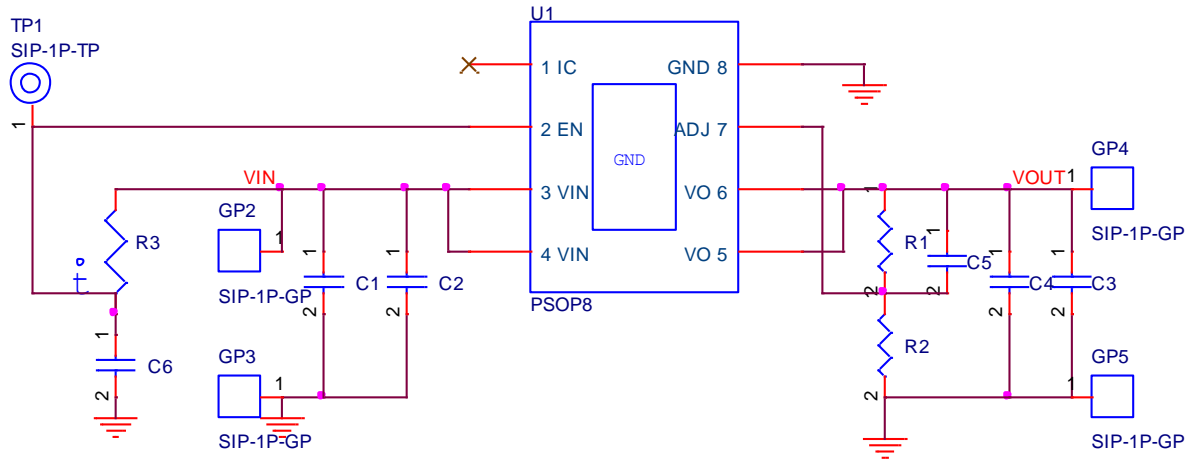

1. The capacitance values of the input and output capacitors will influence the input and output voltage ripple.
2. MLCC capacitors have degrading capacitance at DC bias voltage, and especially smaller size MLCC capacitors will have much lower capacitance.

Measure Result

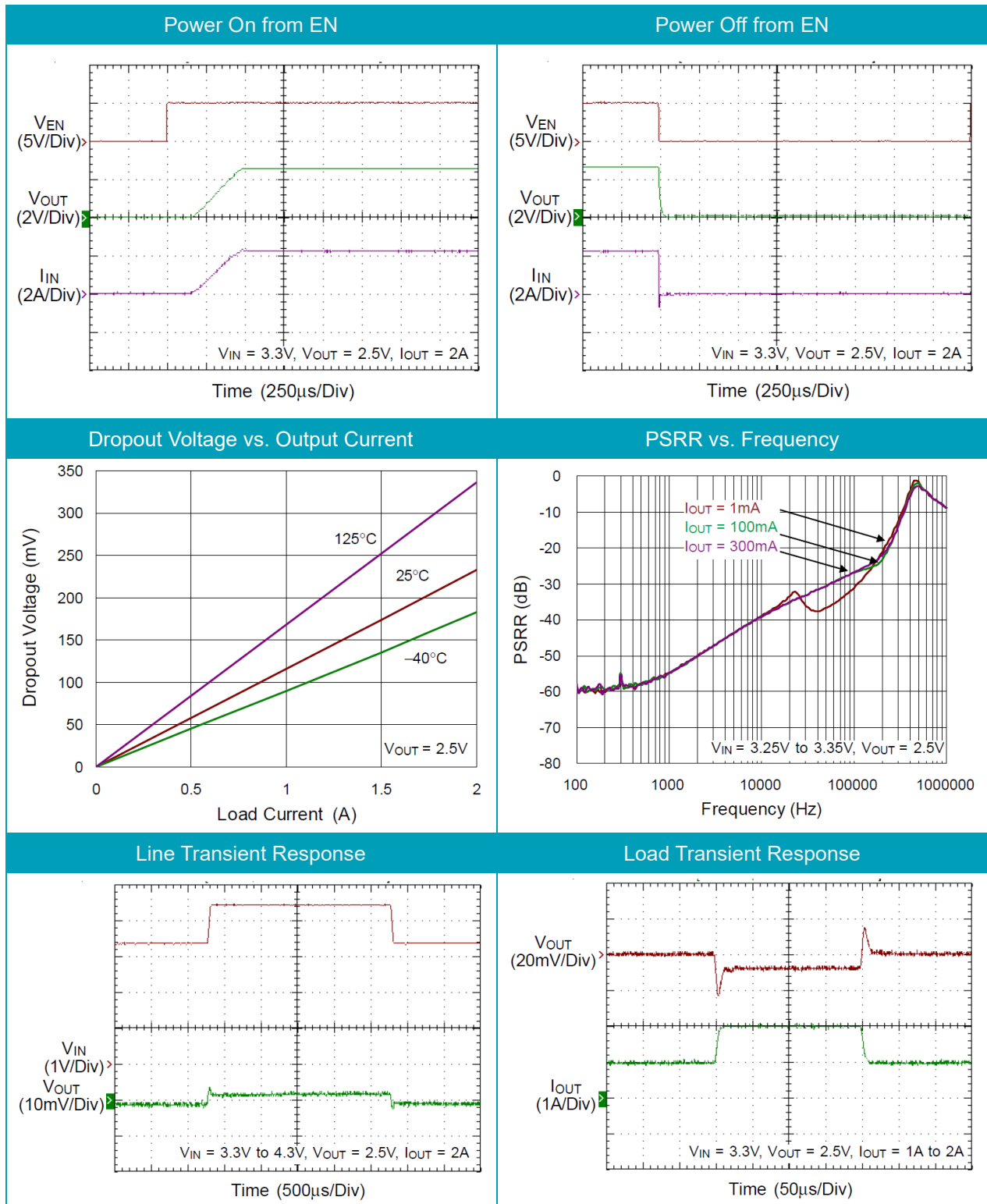

Note:

- When measuring the input or output voltage ripple, care must be taken to avoid a long ground lead on the oscilloscope probe. Measure the output voltage ripple by touching the probe tip directly across the output capacitor.
- The C4 component manufacturer used for these measurements is MURATA.

Evaluation Board Layout

Figure 1 and Figure 2 are RTQ2516 Evaluation Board layout. This board is constructed on two-layer PCB, outer layers with 1 oz. Cu and inner layers with 1 oz. Cu.

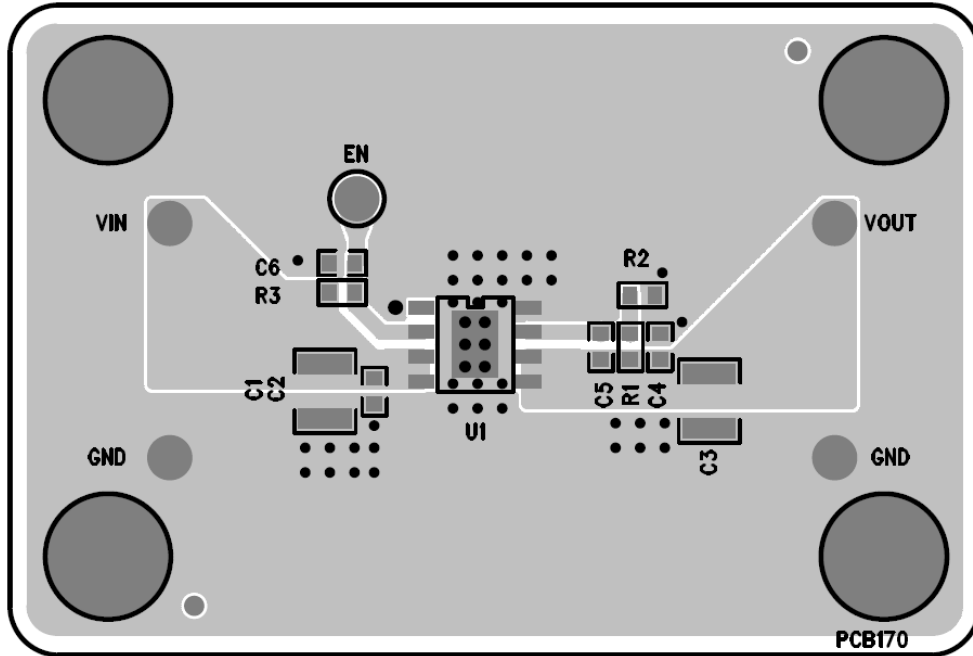

Figure 1. Top View (1st layer)

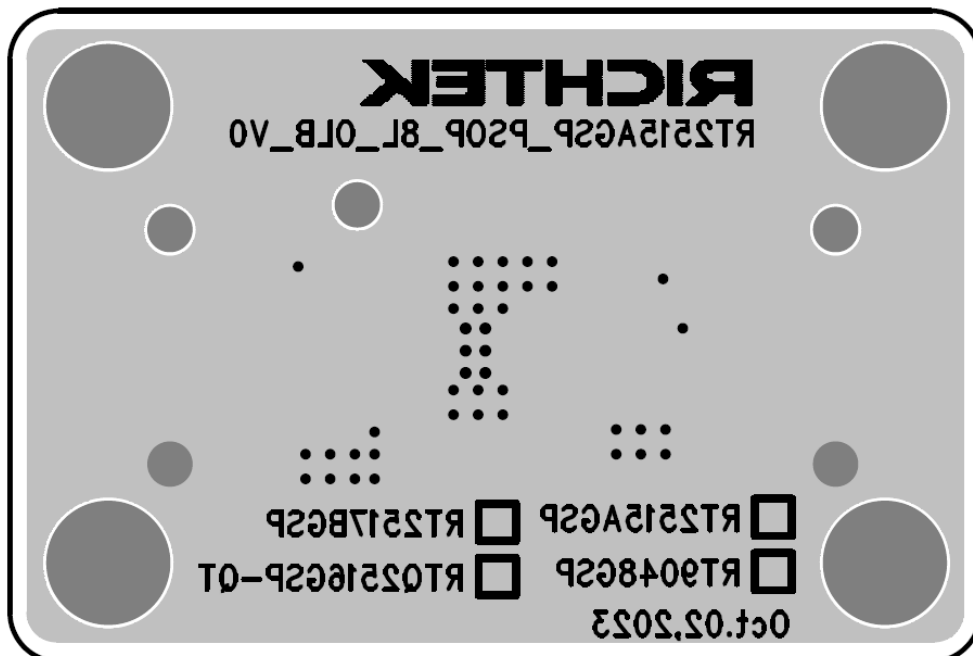

Figure 2. Bottom View (2nd Layer)

More Information

For more information, please find the related datasheet or application notes from Richtek website

<http://www.richtek.com>.

Important Notice for Richtek Evaluation Board

THIS DOCUMENT IS FOR REFERENCE ONLY, NOTHING CONTAINED IN THIS DOCUMENT SHALL BE CONSTRUED AS RICHTEK'S WARRANTY, EXPRESS OR IMPLIED, UNDER CONTRACT, TORT OR STATUTORY, WITH RESPECT TO THE PRESENTATION HEREIN. IN NO EVENT SHALL RICHTEK BE LIABLE TO BUYER OR USER FOR ANY AND ALL DAMAGES INCLUDING WITHOUT LIMITATION TO DIRECT, INDIRECT, SPECIAL, PUNITIVE OR CONSEQUENTIAL DAMAGES.